

## Tectonic LS-218 Sub Woofer Specifications

### General -

- Woofer Size: 18.00" (457mm)
- Voice Coil Diameter: 4.00" (100mm)
- Magnet Type: Neodymium

### Construction Features -

- Hardware/Flyware: (8) Custom Pin Inserts
- Dimensions (inch): 51.8" W x 20.1" H x 47.3" D
- Dimensions (mm): 1300 W x 510 H x 1200 D
- Weight (lbs/kg): 270 lbs (123 Kg)

### Performance Specifications -

- Frequency Response: 28Hz - 120Hz (-3dB)  
22Hz - 160Hz (-10dB)
- One LS Cabinet
  - Sensitivity: 101dB @ 1W / 1 Meter
  - Max SPL Long-term: 140dB
  - Max SPL Peak: 143dB
- Two LS Cabinets
  - Sensitivity: 104dB 1W / 1 Meter
  - Max SPL Long-term: 143dB
  - Max SPL Peak: 146dB

### Settings & Impedance -

- Cross-over Point: 80Hz - 120Hz
- Nominal Impedance: 2 x 8 Ohms

### Amplification -

- Continuous Power Rating: 1200W RMS (ea 8 Ohms)
- Program / Peak Power: 2400W / 3600W (ea 8 Ohms)
- Recommended Amplification: 3200W @ 8 Ohms ea

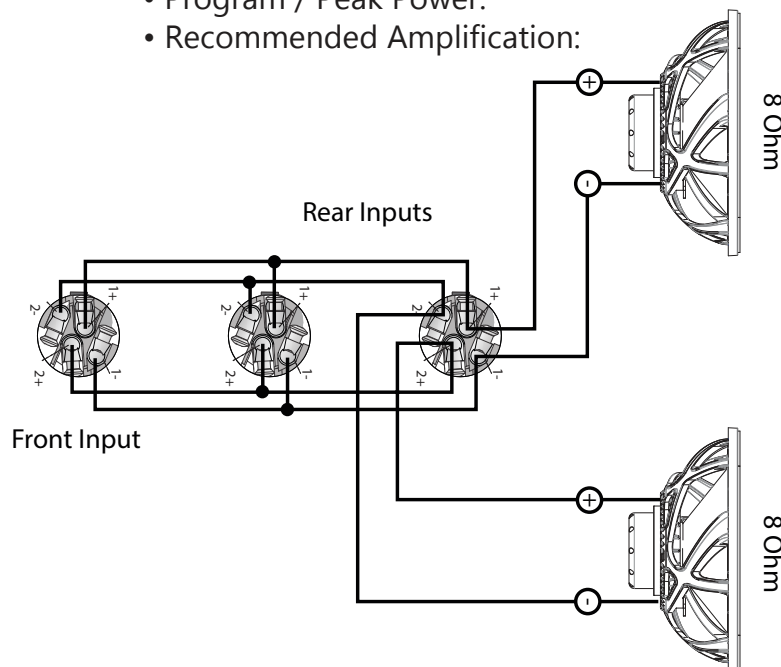

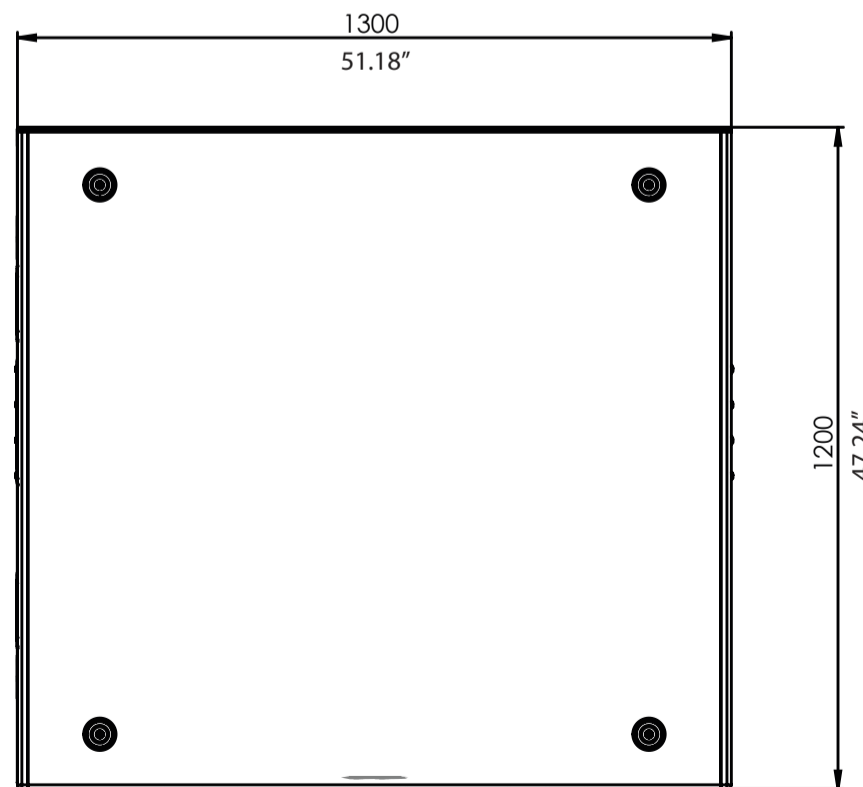
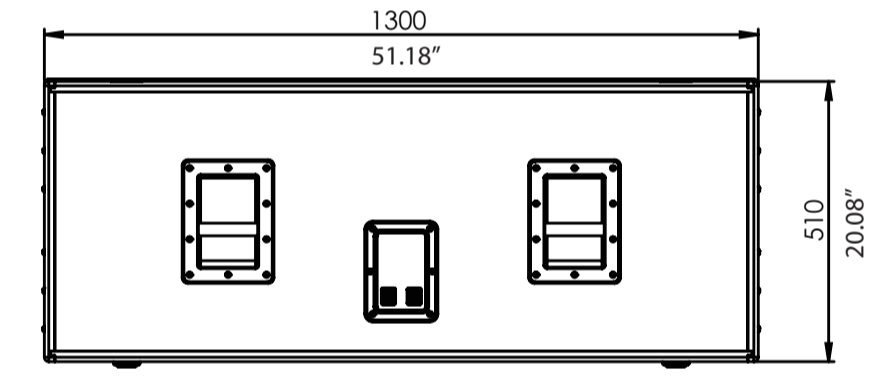
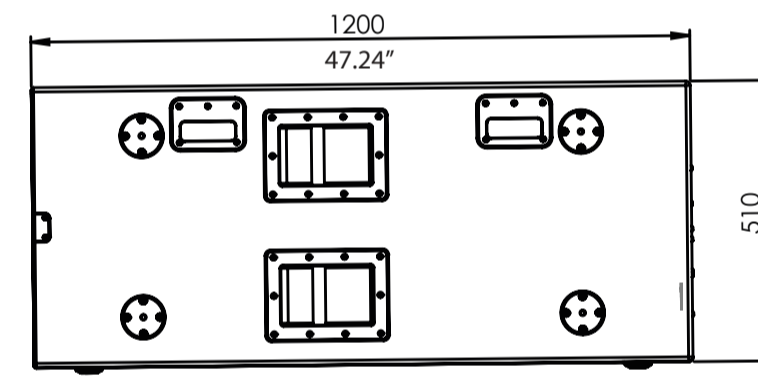
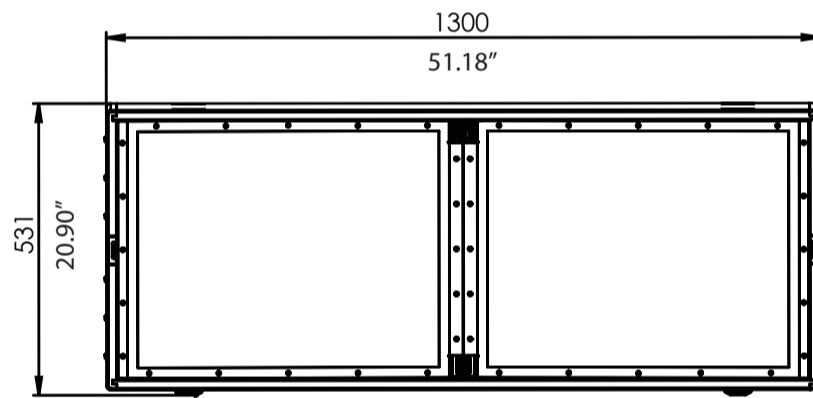
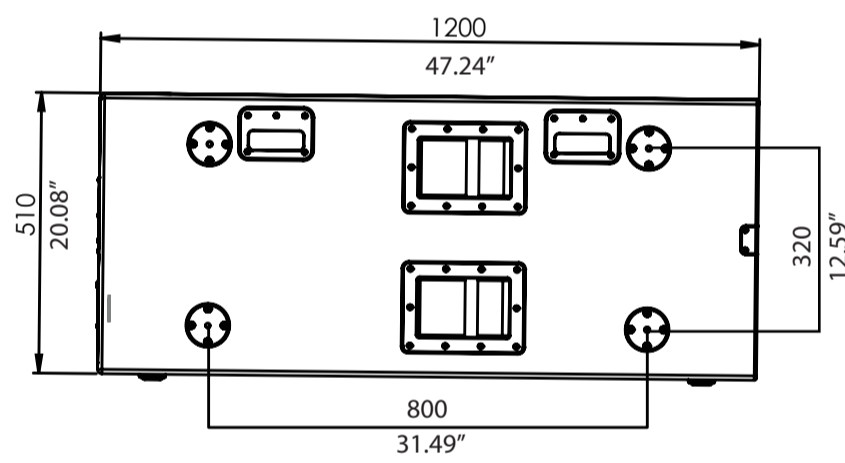
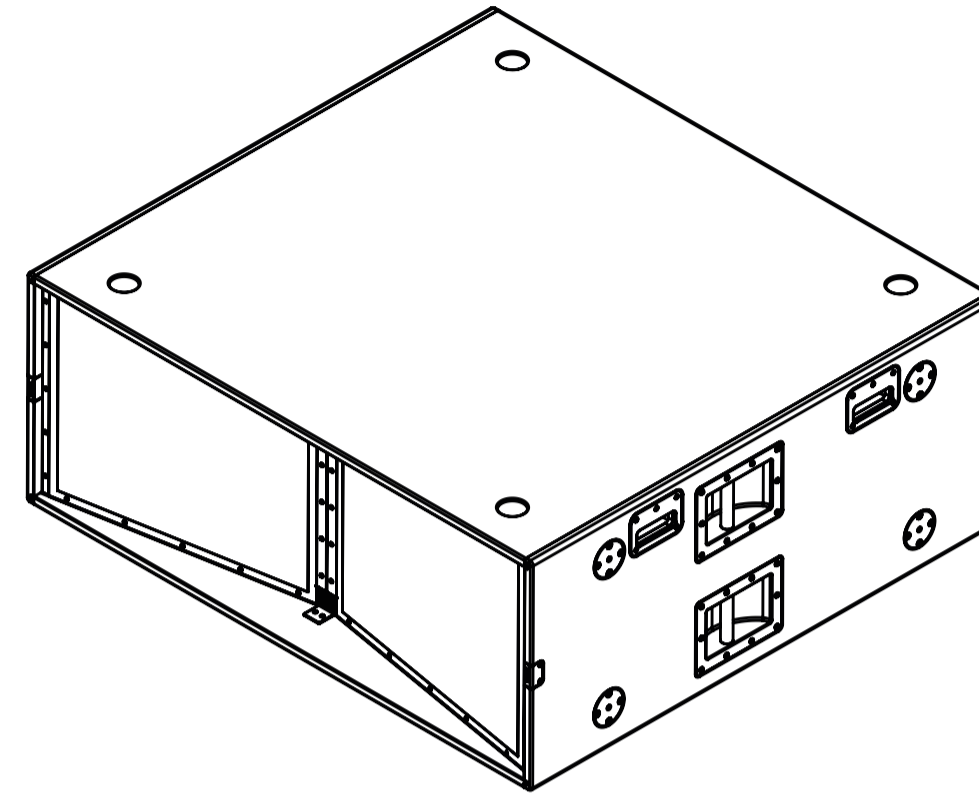
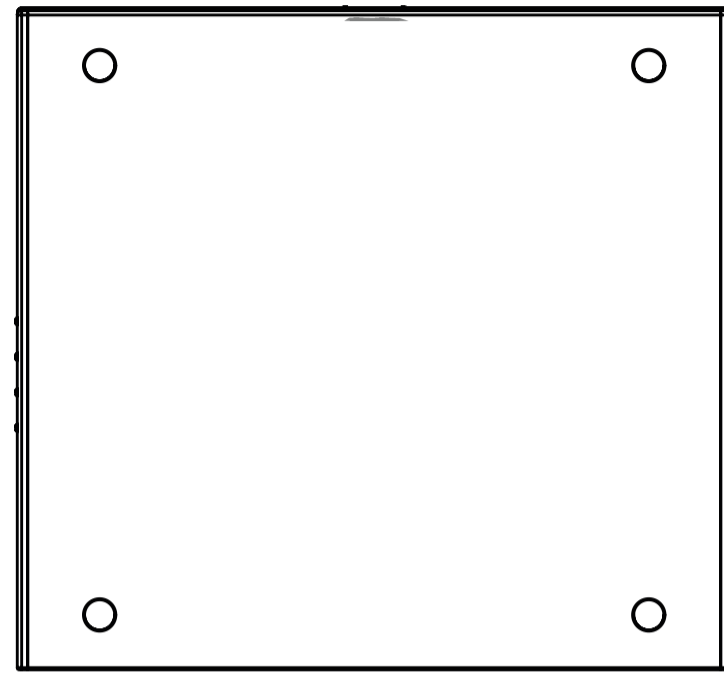

THIRD ANGLE PROJECTION			
DIMENSIONS IN MILLIMETRES			
Tectonic Audio Labs			
MODEL: LS-218			
CAD DRAWING FILE:			
LINE_DRAWING			
CAD MODEL FILE:			
TECTONIC_PANEL_ASSY_V5			
SHEET:	SCALE:	SIZE:	
1 OF 1	3:50	A2	
PROJECT:			
LS-218			
TITLE:			
PANEL LINE DRAWING			
DRAWING NUMBER:	VERSION:	RELEASE:	
			<input type="checkbox"/> <input type="checkbox"/>

©TECTONIC AUDIO 2018. ALL RIGHTS RESERVED. THIS DRAWING AND THE INFORMATION SHOWN THEREIN REMAINS THE PROPERTY OF TECTONIC AUDIO AT ALL TIMES. IT MAY NOT BE MODIFIED, COPIED, DUPLICATED, DISTRIBUTED, REPRODUCED, REPOSTED, DOWNLOADED, DISPLAYED, POSTED, TRANSMITTED, OR SOLD IN ANY FORM OR BY ANY MEANS, IN WHOLE OR IN PART, WITHOUT THE WRITTEN PERMISSION OF TECTONIC AUDIO.



**GENERAL:**

Five year limited component warranty on speaker assemblies and accessories.

**WARRANTY CONDITIONS:**

a. **LIMITED WARRANTY.** Each Authorized Product is sold subject to Tectonic's limited warranty for such Authorized Product then in effect at the time of shipment. Tectonic shall supply any limited warranty with the Authorized Product at the time of shipment. Tectonic may make such warranties available via its website. The limited warranty provided is Tectonic's sole warranty to Dealer or any third party with respect to the Authorized Products.

b. **WHAT IS NOT COVERED BY THE LIMITED WARRANTY:** This warranty does not apply to any other hardware or software products or other items other than the Authorized Products, even if packaged or sold with Authorized Products. Manufacturers, suppliers, or publishers, other than Tectonic, may provide their own warranties to you but Tectonic, in so far as permitted by law, provides any third party products "AS IS". This warranty does not apply: (a) to consumable parts, such as batteries, unless failure has occurred due to a defect in materials or workmanship; (b) to cosmetic damage, including but not limited to scratches and dents; (c) to damage caused by use of the Authorized Product with any other product; (d) to damage caused by accident, abuse, misuse, liquid contact, -re, earthquake or other external cause; (e) to damage caused by operating the Authorized Products outside Tectonic's published specifications; (f) to damage caused by configuration or service to the Authorized Products including upgrades and expansions performed by Dealer or any third party; (g) to an Authorized Product that has been modified to alter functionality or capability without the written permission of Tectonic; (h) to defects caused by normal wear and tear or otherwise due to the normal aging of the Authorized Product; or (i) if any serial number has been removed or defaced from the Authorized Product.

c. **EXCEPT AS SET FORTH IN TECTONIC'S LIMITED WARRANTY, TECTONIC EXPRESSLY DISCLAIMS ALL EXPRESS OR IMPLIED CONDITIONS, REPRESENTATIONS, AND WARRANTIES INCLUDING, WITHOUT LIMITATION, ANY IMPLIED WARRANTY OR CONDITION OF MERCHANTABILITY, FITNESS FOR A PARTICULAR PURPOSE, NON-INFRINGEMENT, SATISFACTORY QUALITY, NON-INTERFERENCE, ACCURACY OF INFORMATIONAL CONTENT, OR ARISING FROM A COURSE OF DEALING, LAW, USAGE, OR TRADE PRACTICE, ARE HEREBY EXCLUDED TO THE EXTENT ALLOWED BY APPLICABLE LAW AND ARE EXPRESSLY DISCLAIMED BY TECTONIC. TO THE EXTENT AN IMPLIED WARRANTY CANNOT BE EXCLUDED, SUCH WARRANTY IS LIMITED IN DURATION TO THE EXPRESS WARRANTY PERIOD. BECAUSE SOME STATES OR JURISDICTIONS DO NOT ALLOW LIMITATIONS ON HOW LONG AN IMPLIED WARRANTY LASTS, THE ABOVE LIMITATION MAY NOT APPLY. THIS WARRANTY GIVES CUSTOMER SPECIFIC LEGAL RIGHTS, AND CUSTOMER MAY ALSO HAVE OTHER RIGHTS WHICH VARY FROM JURISDICTION TO JURISDICTION. This disclaimer and exclusion shall apply even if the express warranty set forth above fails of its essential purpose.**

d. DEALER'S OBLIGATIONS. DEALER SHALL NOT BY STATEMENT OR IMPLICATION, ALTER, ADD TO, AUGMENT OR MISREPRESENT TECTONIC'S LIMITED WARRANTY. DEALER SHALL KEEP RECORDS OF ITS SALE OF ALL AUTHORIZED PRODUCTS WHICH WILL INCLUDE THE NAME AND ADDRESS OF ANY CUSTOMER, THE DATE OF THE SALE, THE MODEL AND SERIAL NUMBERS OF THE AUTHORIZED PRODUCT AND ANY OTHER RELEVANT INFORMATION. DEALER'S SOLE REMEDY FOR ANY BREACH OF TECTONIC'S LIMITED WARRANTY SHALL BE REPAIR OR REPLACEMENT OF DEFECTIVE AUTHORIZED PRODUCTS OR, IN TECTONIC'S SOLE OPTION, THE REFUND OF THE PURCHASE PRICE.

**REPAIR EXPENSES:**

Tectonic will pay all labor and material expenses for all repairs covered by this warranty. Please be sure to save the original shipping cartons. A charge be made if replacement cartons are requested. Payment of shipping charges is discussed in the next section of this warranty.

**OBTAINING WARRANTY PERFORMANCE**

If your Tectonic product needs service, write or telephone us at Tectonic Audio Labs – attn: Customer Service – 17802 134<sup>th</sup> Ave. NE, Suite 20, Woodinville, WA 98072 +425-686-7640. You must present the original bill of sale to establish the date of purchase. Please do not ship your Tectonic product to the factory without prior authorization.

You are responsible for transporting your product for repair or arranging for its transportation and for payment of any initial shipping charges. Tectonic will pay the return shipping charges if repairs are covered by the warranty.

Tectonic Audio Labs • 17802 134th Ave. NE • Suite 20 • Woodinville, WA 98072 USA

+425-686-7640 p +425-949-7447 f